

**Cryogenic Top-Entry  
 Two-Way Ball Valve  
 Fully Bidirectional**

**Series 67-K**

**DN 1" to 8"**

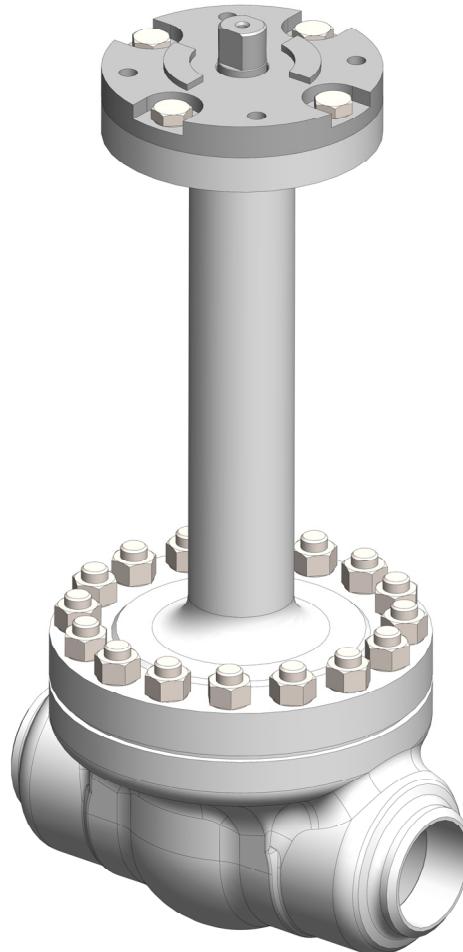

**Description:**

This PERRIN ball valve design features a one piece, bolted body, a extension for insulation and a floating, seat supported ball. The seat system is spring loaded, cavity relief and fully bi-directional suitable up to full  $\Delta p$ . The valve is designed acc. low temperature standards BS 6364, EN 1626, ISO 28921 and OCIMF. The stem sealing is spring loaded.

The actuator mounting flange corresponds to the NAMUR recommendations with dimensions according DIN/EN/ISO 5211.

Locking devices and actuators with accessories can be mounted at any time.

The ball valve incorporates an anti-static design, with anti-blowout stem, fugitive emission tested acc. ISO 15848-1 and fire-safe tested according ISO 10497 and API 607.

**Range of application:**

DN 1" to 8"	PN ANSI Cl. 150/1500	Temperature -196°C to 100°C -320°F to 212°F
----------------	-------------------------	---

### 1.0 Main parts

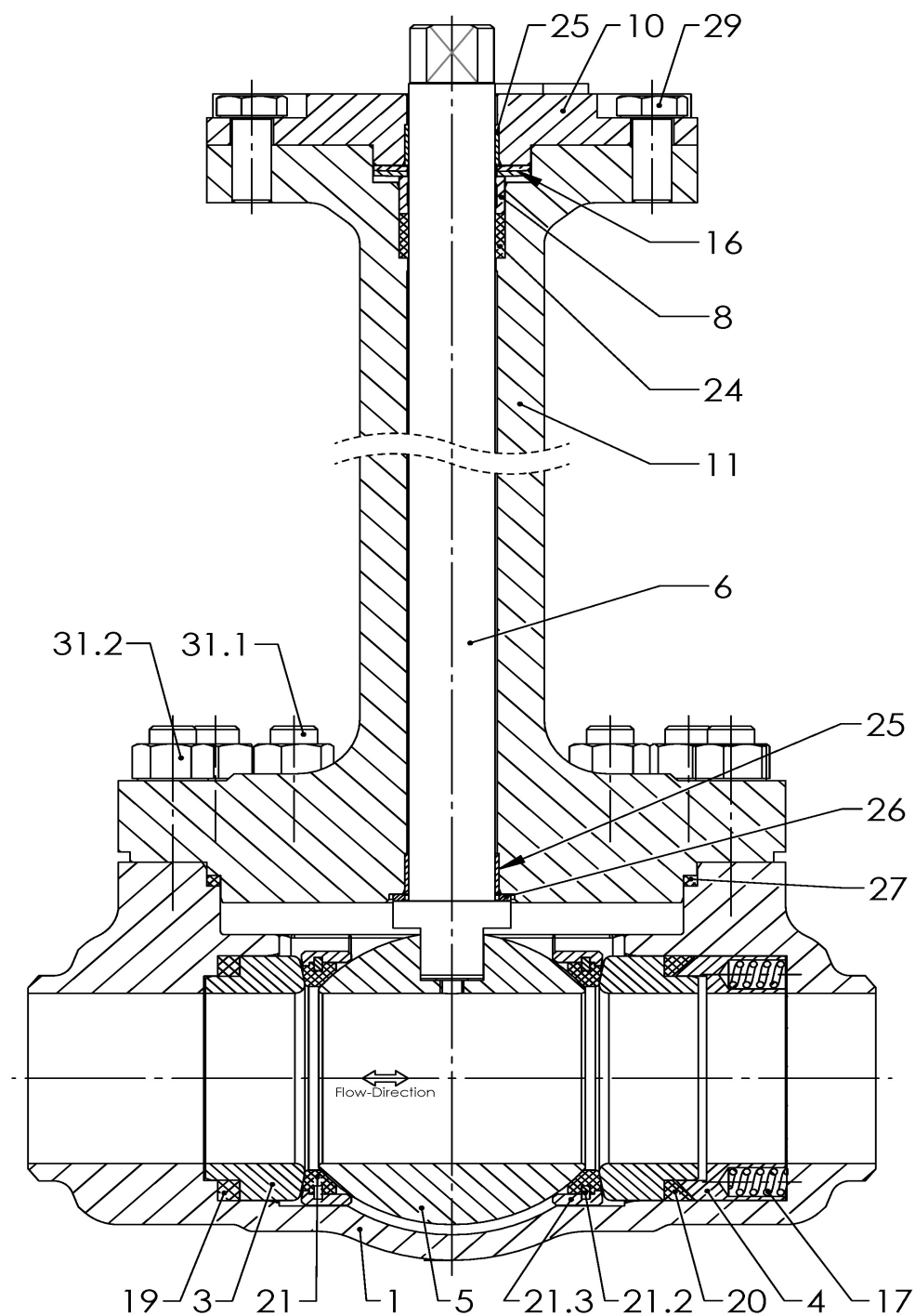

Technical modifications are reserved.

**1.1 Materials**

item	designation	materials acc. EN / ASTM	
		-196°C to 100°C -320°F to 212°F	-196°C to 100°C -320°F to 212°F
1	body	1.4408 / 1.4409	A351 CF8M / A351 CF3M
3	dome ring	1.4401/04	A182 F316/F316L
4	retainer ring	1.4401/04	A182 F316/F316L
5	ball	1.4408 / 1.4409	A351 CF8M / A351 CF3M
6	stem	1.4980	UNS S66286
8	gland washer	1.4401/04	A182 F316/F316L
10	bearing cover	1.4401/04	A182 F316/F316L
11	extension	1.4408 / 1.4409	A351 CF8M / A351 CF3M
16	plate spring	1.4310	A182 F301
17	coil spring	1.4571	A182 F316
19-20	sealing ring	Graphite	Graphite
21	seat ring	PCTFE	PCTFE
21.2	snap ring	1.4310	A182 F301
21.3	distance ring	1.4401/04	A182 F316/F316L
24	stem packing	Graphite	Graphite
25	cyl. bush	PTFE with 1.4301	PTFE with A182 F304
26	disk	PTFE with 1.4301	PTFE with A182 F304
27	body gasket	Graphite	Graphite
30	hexagon screw	A193 B8M Cl. 2	A193 B8M Cl. 2
30.1	stud	A193 B8M Cl. 2	A193 B8M Cl. 2
30.2	hexagon nut	A193 B8M Cl. 2	A193 B8M Cl. 2

All EN materials are equivalent to the above mentioned ASTM materials.

## 2.0 Technical data

### 2.1 Dimensional Drawing and Topwork

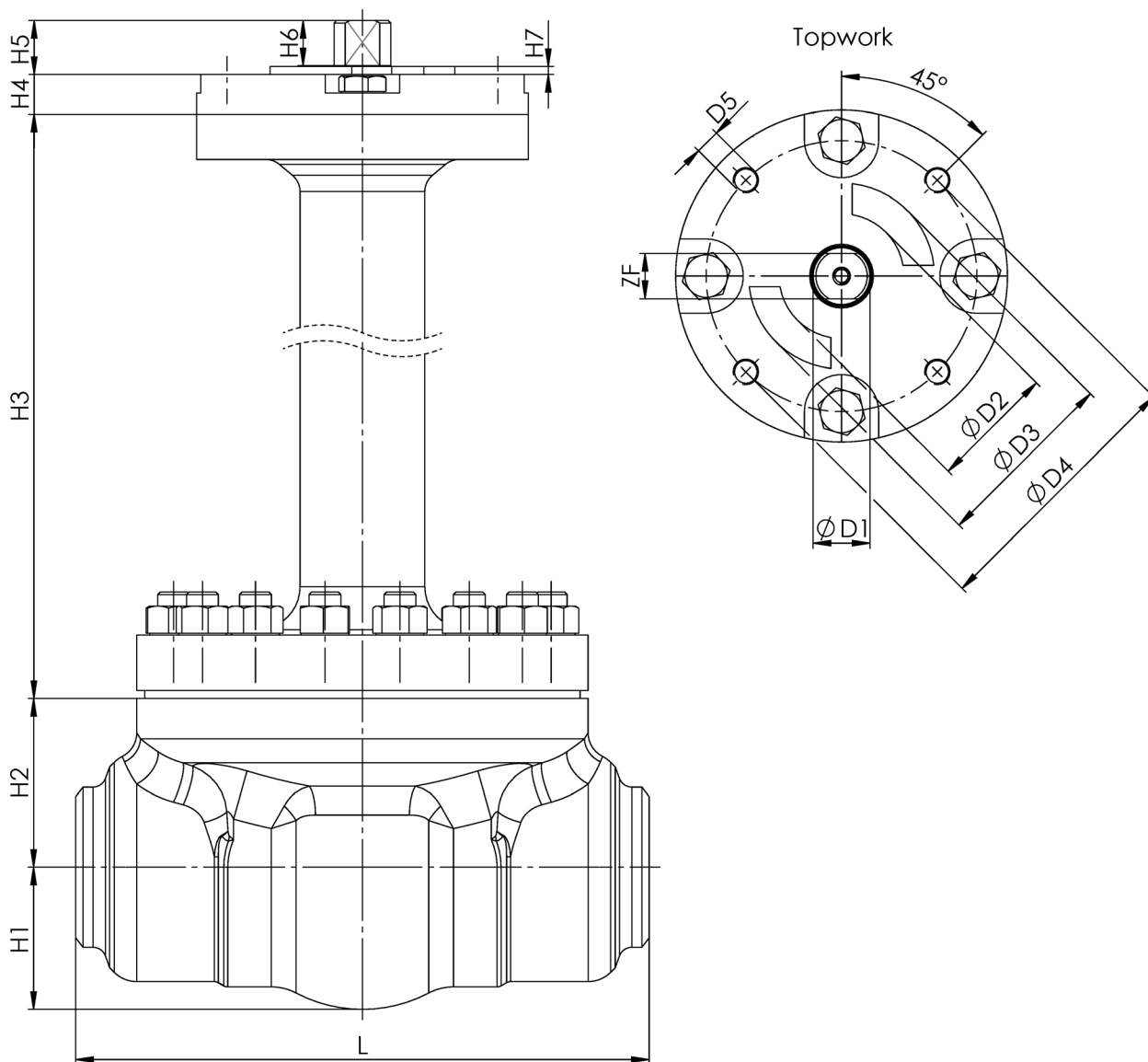

## 2.2 Nominal size / Main-Dimensions / Weights / Flow

### Class 150

Nominal size (DN)		dimensions [mm] [in.]														weight [kg]	flow $k_{v100}$ Cv	actuator connection DIN/EN/ISO5211
		H1	H2	H3	H4	H5	H6	H7	øD1	øD2	øD3	øD4	øD5	ZF	L			
1"	25	41 1,61	42 1,65	230 9,05	12 0,47	19,5 0,76	18 0,71	3 0,12	13 0,51	26 1,02	35 1,38	50 1,97	M6	10 0,39	165 6,5	6,7	65 76	F05
1½"	40	57 2,24	58 2,28	284 11,18	14 0,55	20,7 0,81	14 0,55	3 0,12	18 0,71	--	55 2,16	70 2,75	M8	10 0,39	190 7,5	15	165 191	F07
2"	50	54 2,13	64 2,52	287 11,3	15 0,59	20 0,78	17 0,67	3 0,12	21,4 0,84	47 1,85	70 2,75	102 4,01	M10	17 0,67	216 8,5	20,4	258 298	F10
2½"	65	76 3	68 2,67	291 11,45	15 0,59	20 0,78	17 0,67	3 0,12	21,4 0,84	47 1,85	70 2,75	102 4,01	M10	17 0,67	241 9,5	22,4	436 504	F10
3"	80	90 3,54	73 2,87	365 14,37	21 0,83	26 1,02	22 0,86	3 0,12	28 1,1	60 2,36	85 3,34	125 4,92	M12	22 0,86	282 11,1	34,1	660 763	F12
4"	100	93,5 3,68	87 3,42	375 14,76	26 1,02	36,3 1,43	31 1,22	4 0,16	36 1,42	--	100 3,94	140 5,51	M16	27 1,06	305 12	60,6	1031 1192	F14
6"	150	149 5,86	115 4,52	455 17,91	30 1,18	114 4,49	107 4,21	5 0,16	44 1,73	--	130 5,12	165 6,5	M20	1).	405 15,95	113	2320 2682	F16
8"	200	175 6,89	140 4,51	467 18,38	30 1,18	106 4,17	100 3,94	5 0,16	50 1,96	--	130 5,12	165 6,5	M20	1).	521 20,5	214	4124 4767	F16

1). = with feather key

### Class 300

Nominal size (DN)		dimensions [mm] [in.]														weight [kg]	flow $k_{v100}$ Cv	actuator connection DIN/EN/ISO5211
		H1	H2	H3	H4	H5	H6	H7	øD1	øD2	øD3	øD4	øD5	ZF	L			
1"	25	41 1,61	42 1,65	230 9,05	12 0,47	19,5 0,76	18 0,71	3 0,12	13 0,51	26 1,02	35 1,38	50 1,97	M6	10 0,39	165 6,5	6,7	65 76	F05
1½"	40	57 2,24	58 2,28	284 11,18	14 0,55	20,7 0,81	14 0,55	3 0,12	18 0,71	--	55 2,16	70 2,75	M8	10 0,39	190 7,5	15	165 191	F07
2"	50	54 2,13	64 2,52	287 11,3	15 0,59	20 0,78	17 0,67	3 0,12	21,4 0,84	47 1,85	70 2,75	102 4,01	M10	17 0,67	216 8,5	20,4	258 298	F10
2½"	65	77,5 3,05	68 2,67	308 12,12	21 0,83	26 1,02	22 0,86	3 0,12	28 1,1	--	85 3,34	125 4,92	M12	22 0,86	241 9,5	28,6	436 504	F12
3"	80	85 3,34	73 2,87	382 15,04	26 1,02	36,3 1,43	31 1,22	4 0,16	36 1,42	--	100 3,94	140 5,51	M16	27 1,06	282 11,1	48,7	660 763	F14
4"	100	93,5 3,68	87 3,42	375 14,76	26 1,02	36,3 1,43	31 1,22	4 0,16	36 1,42	--	100 3,94	140 5,51	M16	27 1,06	305 12	60,6	1031 1192	F14
6"	150	153 6,02	115 4,52	452 17,79	30 1,18	107 4,01	100 3,94	5 0,16	50 1,96	--	130 5,12	165 6,5	M20	1).	405 15,95	152	2320 2682	F25
8"	200	175 6,89	145 5,70	491 19,33	30 1,18	199 7,83	190 7,48	5 0,16	68 2,68	--	230 9,05	298 11,73	M20	1).	521 20,5	310	4124 4767	F30

1). = with feather key

### Class 600

Nominal size (DN)		dimensions [mm] [in.]														weight [kg]	flow $k_{v100}$ Cv	actuator connection DIN/EN/ISO5211
		H1	H2	H3	H4	H5	H6	H7	øD1	øD2	øD3	øD4	øD5	ZF	L			
1"	25	41 1,61	42 1,65	239 9,41	14 0,55	17,9 0,70	14 0,55	3 0,12	18 0,71	--	55 2,16	70 2,75	M8	10 0,39	254 10	12	65 76	F07
1½"	40	57 2,24	58 2,28	288 11,33	15 0,59	18,3 0,72	17 0,67	3 0,12	21,4 0,84	47 1,85	70 2,75	102 4,01	M10	17 0,67	241 9,5	21,5	165 191	F10
2"	50	55 2,16	67,6 2,66	298 11,74	21 0,83	27,3 1,07	22 0,86	3 0,12	28 1,1	--	85 3,34	125 4,92	M12	22 0,86	292 11,5	29,8	258 298	F12

Technical modifications are reserved.

**Class 900**

Nominal size (DN)		dimensions [mm] [in.]													weight [kg]	flow $K_{v100}$ Cv	actuator connection DIN/EN/ISO5211	
		H1	H2	H3	H4	H5	H6	H7	øD1	øD2	øD3	øD4	øD5	ZF				L
1"	25	41 1,61	42 1,65	239 9,41	14 0,55	17,9 0,70	14 0,55	3 0,12	18 0,71	--	55 2,16	70 2,75	M8	10 0,39	254 10	12	65 76	F07
1½"	40	57 2,24	58 2,28	303 11,93	21 0,83	26,5 1,04	22 0,86	3 0,12	28 1,1	--	85 3,34	125 4,92	M12	22 0,86	305 12	29,2	165 191	F12
2"	50	58,5 2,30	67,6 2,66	306 12,05	26 1,02	36,3 1,43	31 1,22	4 0,16	36 1,42	--	100 3,94	140 5,51	M16	27 1,06	368 14,5	39,3	258 298	F14

**Class 1500**

Nominal size (DN)		dimensions [mm] [in.]													weight [kg]	flow $K_{v100}$ Cv	actuator connection DIN/EN/ISO5211	
		H1	H2	H3	H4	H5	H6	H7	øD1	øD2	øD3	øD4	øD5	ZF				L
1"	25	52 2,04	49 1,93	236 9,29	15 0,59	18,3 0,72	17 0,67	3 0,12	21,4 0,84	47 1,85	70 2,75	102 4,01	M10	17 0,67	254 10	24	65 76	F10
1½"	40	71,4 2,81	67,6 2,66	312 12,28	26 1,02	36,3 1,43	31 1,22	4 0,16	36 1,42	--	100 3,94	140 5,51	M16	27 1,06	305 12	39	165 191	F14
2"	50	85 3,34	89 3,50	320 12,59	30 1,18	114 4,49	107 4,21	5 0,16	44 1,73	--	130 5,12	165 6,5	M20	1).	368 14,5	91,5	258 298	F16

1). = with feather key

**2.3 Pressure-temperature-diagram**

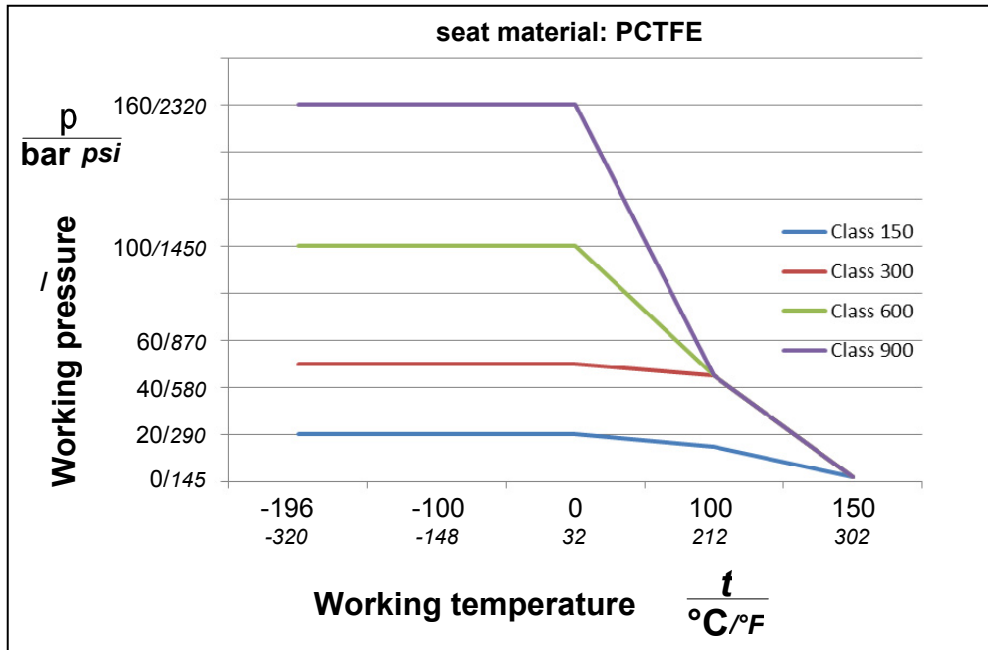

**2.3 Advantages**

- easy assembling / disassembling
- fully bidirectional
- in-house cryogenic testing
- with cavity pressure relief
- life loaded stem packing
- anti blowout stem
- inline maintenance
- ISO connection for actuators and accessories

**2.4 Certifications**

- fire safe acc. DIN EN ISO 10497
- fugitive emission acc. DIN EN ISO 15848-1



